



BEYOND THE EXPECTED™

CURVED BOOM LOADER SPECIFICATIONS

CL100 (Fits Sc2400)

A	Maximum Lift Height @ Pivot Point	71"
B	Maximum Lift Height Under Bucket	66"
C	Dump Clearance	54"
D	Reach @ Maximum Height	28.5"
E	Maximum Dump Angle	45 degrees
F	Reach w/Bucket on Ground	40"
G	Maximum Rollback Angle	25 degrees
	Digging Depth	6"
	Overall Height in Carry Position	37"
	Length of Attachment (Bucket Bottom)	19.5"
	Bucket Width/Weight	48" / 130 lbs.
	Bucket Capacity	5 cu. ft.
	Lift Capacity @ Pivot Pins, Maximum Height	700 lbs.
	Lift Capacity 500 mm Forward of the Pivot Pins, Maximum Height	550 lbs.
	Breakout Force at Bucket Pins	1,350 lbs.
	Raising Time to Full Height w/o Load	3.5 sec.
	Lowering Time w/o Load (Power Down)	2.5 sec.
	Attachment Rollback Time	2 sec.
	Attachment Dumping Time	1.5 sec.
	Rated Flow	3.5 GPM
	Relief Valve	1,780 PSI
	Residential/Commercial Warranty*	1-year limited

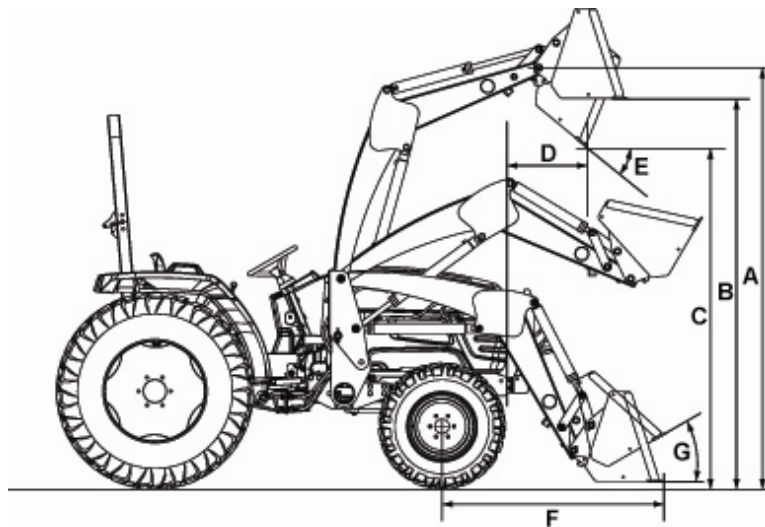

* See owner's manual for warranty detail



BEYOND THE EXPECTED™

CURVED BOOM LOADER SPECIFICATIONS

CL300 (Fits Ex2900 / Ex3200)

A	Maximum Lift Height @ Pivot Point	96"
B	Maximum Lift Height under Bucket	91"
C	Dump Clearance	80"
D	Reach @ Maximum Height	25"
E	Maximum Dump Angle	45 degrees
F	Reach w/Bucket on Ground	58"
G	Maximum Rollback Angle	25 degrees
	Digging Depth	4"
	Overall Height in Carry Position	50"
	Length of Attachment (Bucket Bottom)	21.5"
	Bucket Width / Weight	60"/205 lbs
	Bucket Capacity	7 cu. ft.
	Lift Capacity @ Pivot Pins, Maximum Height	900 lbs.
	Lift Capacity 500 mm Forward of the Pivot Pins, Maximum Height	770 lbs.
	Breakout Force at Bucket Pivot Pin	2,550 lbs.
	Raising Time to Full Height w/o Load	4 sec.
	Lowering Time w/o Load (Power Down)	2.5 sec.
	Attachment Rollback Time	2 sec.
	Attachment Dumping Time	1.5 sec.
	Rated Flow	5.6 GPM
	Relief Valve	2,062 PSI
	Loader Weight w/o Bucket	645 lbs.
	Residential/Commercial Warranty*	1-year limited

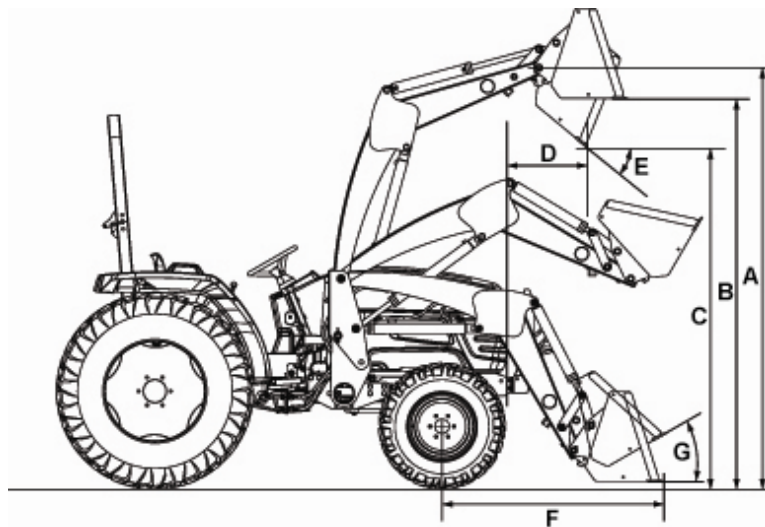

* See owner's manual for warranty detail



BEYOND THE EXPECTED™

CURVED BOOM LOADER SPECIFICATIONS

CL400 (Fits Ex450)

	<u>CL400</u>
A Maximum Lift Height to Bucket Pivot Pin	104.3"
B Maximum Lift Height @ bottom of Bucket	96.5"
C Dump Clearance	84"
D Reach @ Maximum Height	19"
E Maximum Dump Angle	40 degrees
F Reach w/Bucket on Ground	55.7"
G Maximum Rollback Angle	30 degrees
Digging Depth @ Bucket Level	5.9"
Maximum Lift @ Pivot Pins	1,692 lbs.
Maximum Lift 500 mm Forward of the Pivot Pins	1,225 lbs.
Lift Capacity to 59" @ Pivot Pins	1,971 lbs.
Lift Capacity 59" at 500 mm Forward of the Pivot Pins	1,551 lbs.
Overall Height in Carry Position	55.9"
Bucket Width / Weight	72"/275 lbs.
Bucket Capacity	10.6 cu. ft.
Lift Capacity (Bucket Center)	1,375 lbs.
Breakout Force 500 mm Forward of the Pivot Pins	2,042 lbs.
Breakout Force at Bucket Pins	2,728 lbs.
Raising Time to Full Height w/o Load	2.93 sec.
Lowering Time w/o Load (Power Down)	2.04 sec.
Attachment Rollback Time	2.84 sec.
Attachment Dumping Time	1.73 sec.
Rated Flow	8.5 GPM
Relief Valve	2,550 PSI
Loader Weight w/o Bucket	680 lbs.
Loader Valve	Optional
Grille Guard	Standard
Residential/Commercial Warranty*	1-year limited

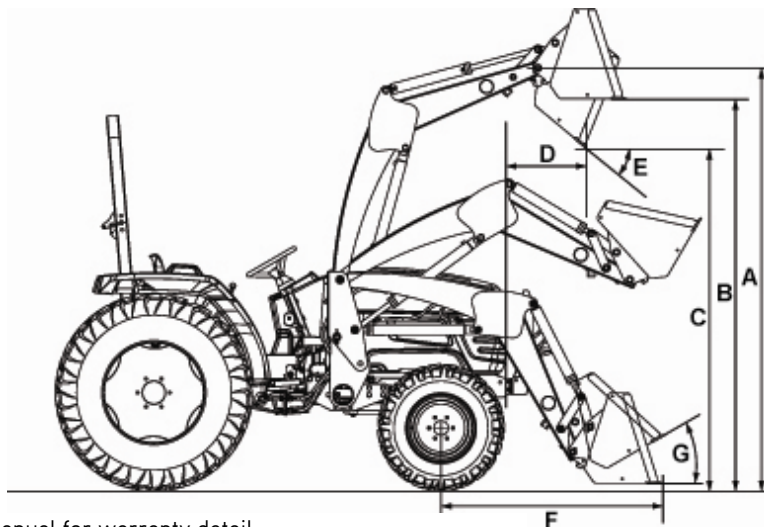

* See owner's manual for warranty detail